

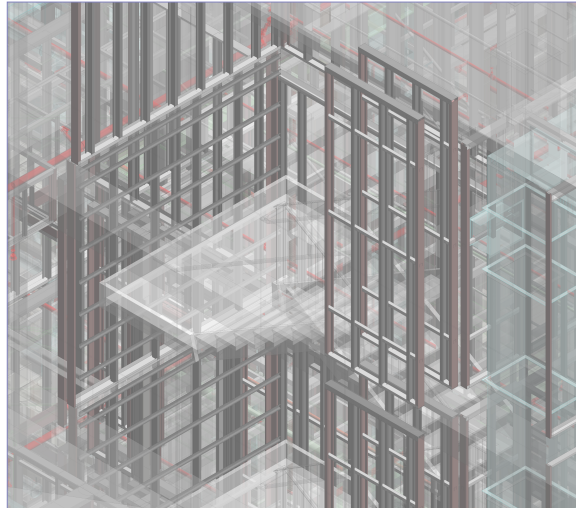

RFrame LLC
WE BUILD IT FIRST.

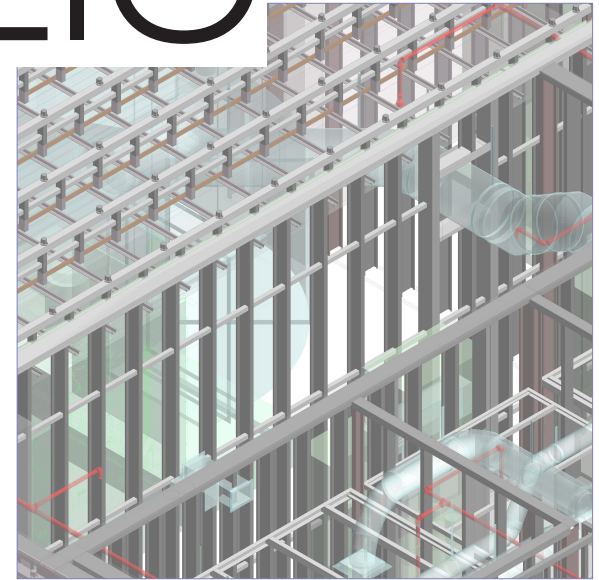

PORTFOLIO

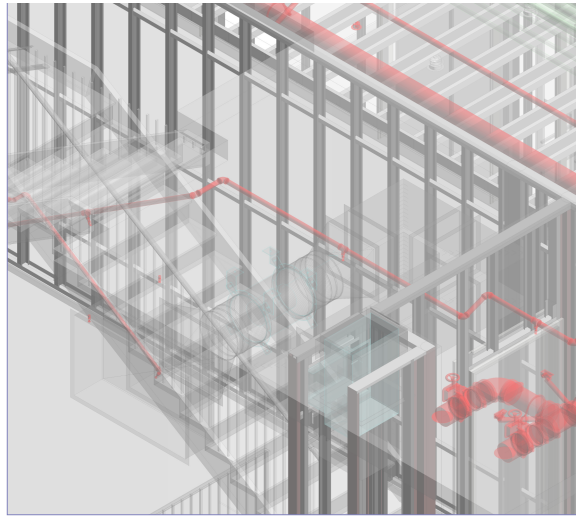
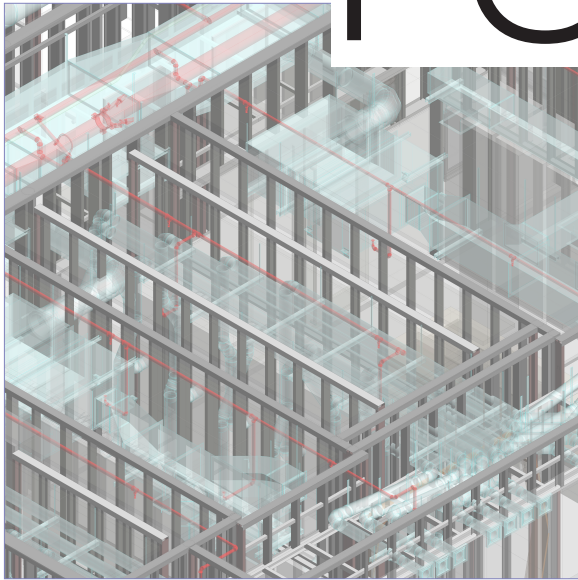



RFrame LLC
WE BUILD IT FIRST.

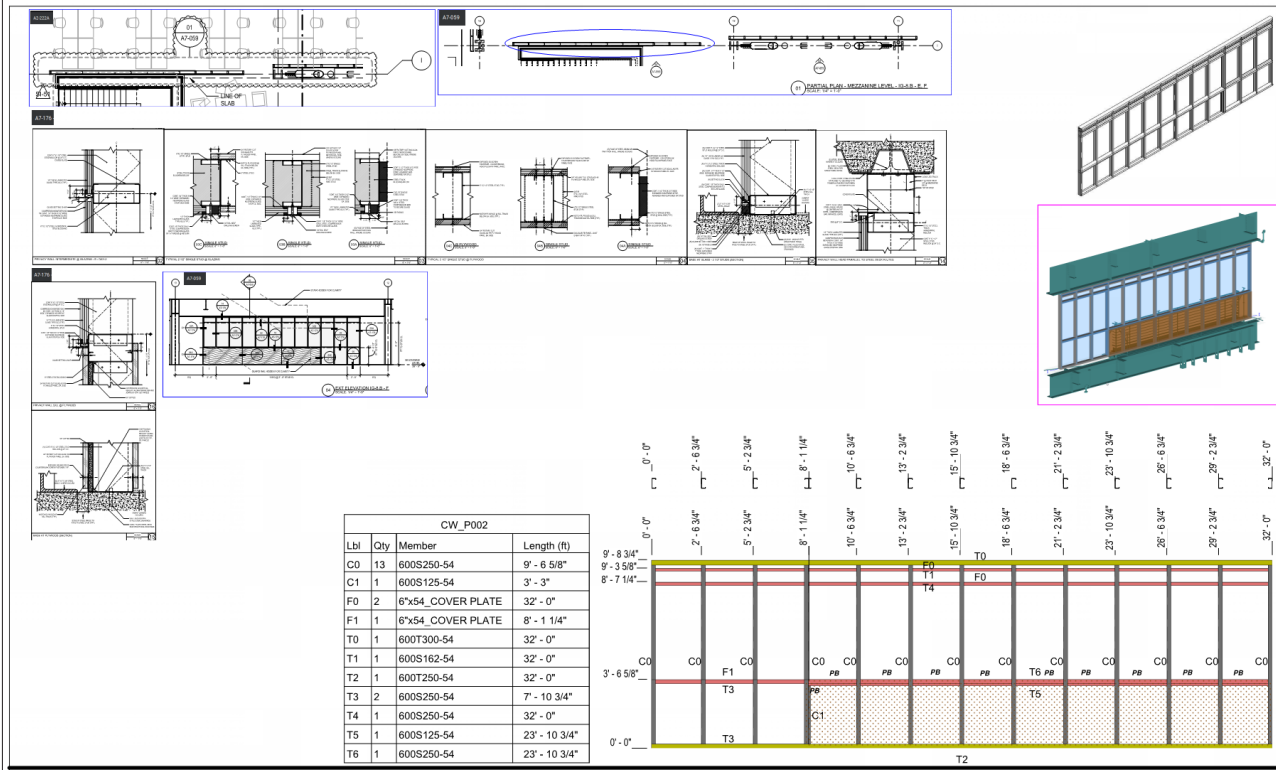

Arch details added in Panel drawings for quick reference

SCOPE: Wall and ceiling framing with MEPF coordination.
Producing panel drawings for site execution.
AREA: 524,000 SF
LEVELS: 5

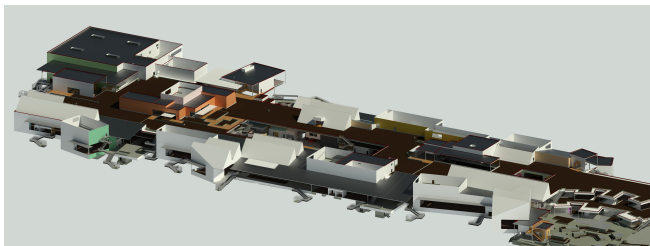
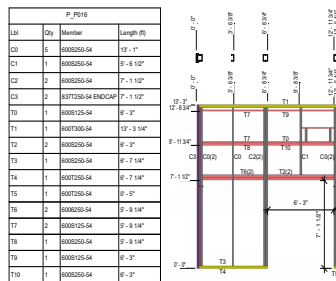

OFFICE BUILDING, MENLO PARK, CA

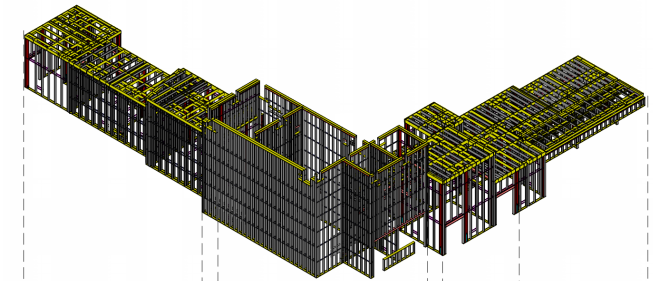

POD 47B1 OVERALL VIEW
2 PATB1.1

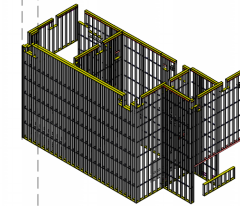

POD 47B1 - EXPLODE VIEW OF NON BEARING WALLS
7 PATB1.1

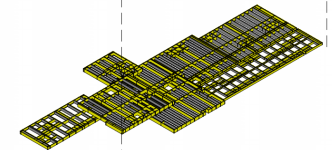
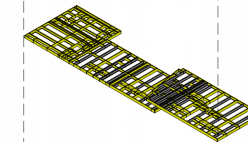

POD 47B1 - EXPLODE VIEW OF LIDS
5 PATB1.1

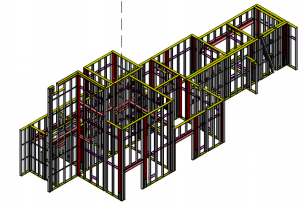
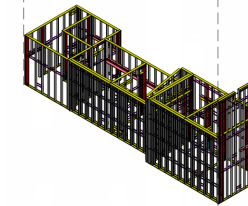

POD 47B1 - EXPLODE VIEW OF BEARING WALLS
6 PATB1.1



RFrame LLC
WE BUILD IT FIRST.

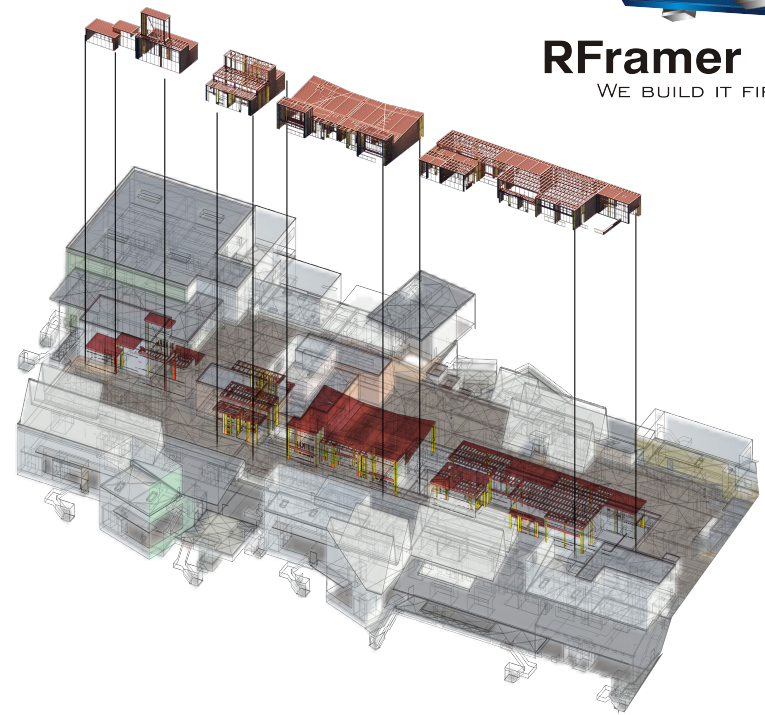

Color	Material
Blue	Structural Steel
Yellow	Concrete
Red	Roofing
Green	MEPF
Purple	Other

Color	Material
Blue	Structural Steel
Yellow	Concrete
Red	Roofing
Green	MEPF
Purple	Other

POD 20 - ZONE B -
LEVEL 1 - WALL
PANELS

ID	Qty	Material	Length
1	1	000112000	11' 11 1/2"
2	1	000112000	11' 11 1/2"
3	1	000112000	11' 11 1/2"
4	1	000112000	11' 11 1/2"
5	1	000112000	11' 11 1/2"
6	1	000112000	11' 11 1/2"
7	1	000112000	11' 11 1/2"
8	1	000112000	11' 11 1/2"
9	1	000112000	11' 11 1/2"
10	1	000112000	11' 11 1/2"
11	1	000112000	11' 11 1/2"
12	1	000112000	11' 11 1/2"
13	1	000112000	11' 11 1/2"
14	1	000112000	11' 11 1/2"
15	1	000112000	11' 11 1/2"
16	1	000112000	11' 11 1/2"
17	1	000112000	11' 11 1/2"
18	1	000112000	11' 11 1/2"
19	1	000112000	11' 11 1/2"
20	1	000112000	11' 11 1/2"

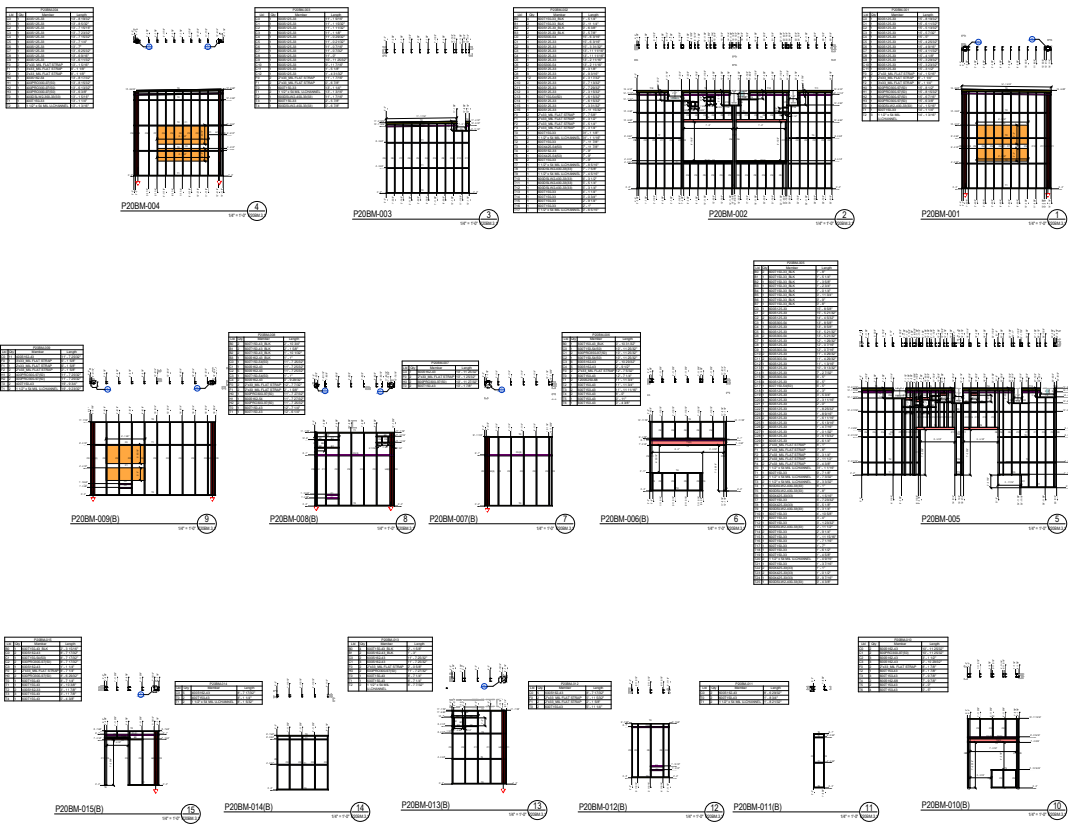

SCOPE: Wall and ceiling framing with MEPF coordination.
Producing panel drawings for site execution.
AREA: 524,000 SF
LEVELS: 5

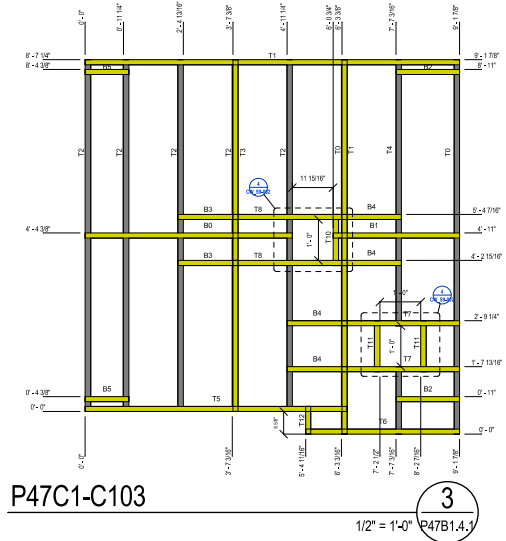
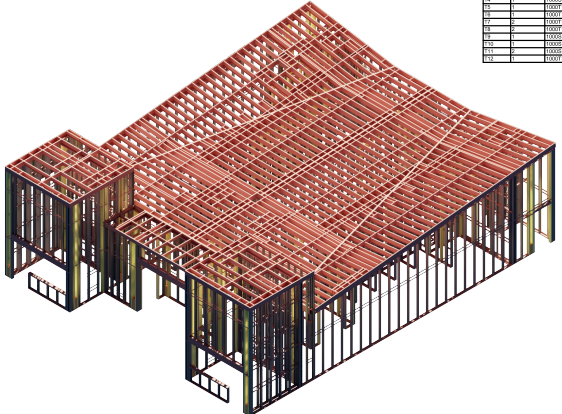



RFrame LLC
WE BUILD IT FIRST.

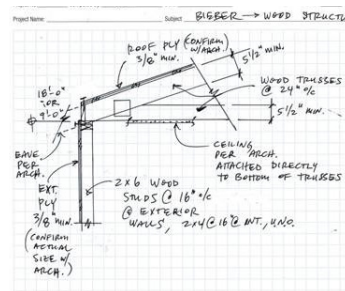
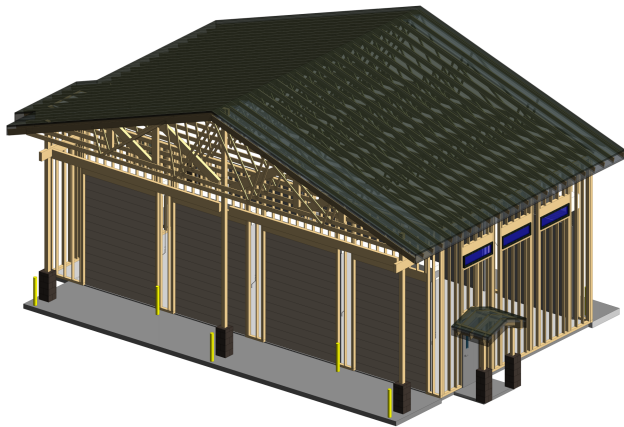
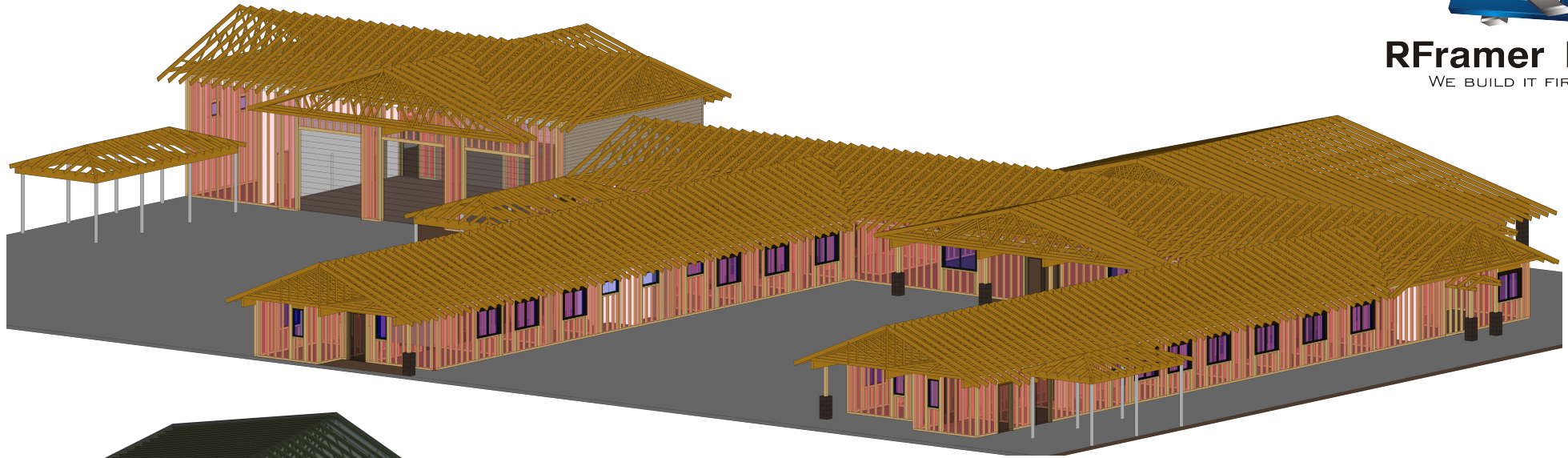

Framing modeled per hand sketches

SCOPE: Structural framing
AREA: 31,663 SF
LEVELS: 1

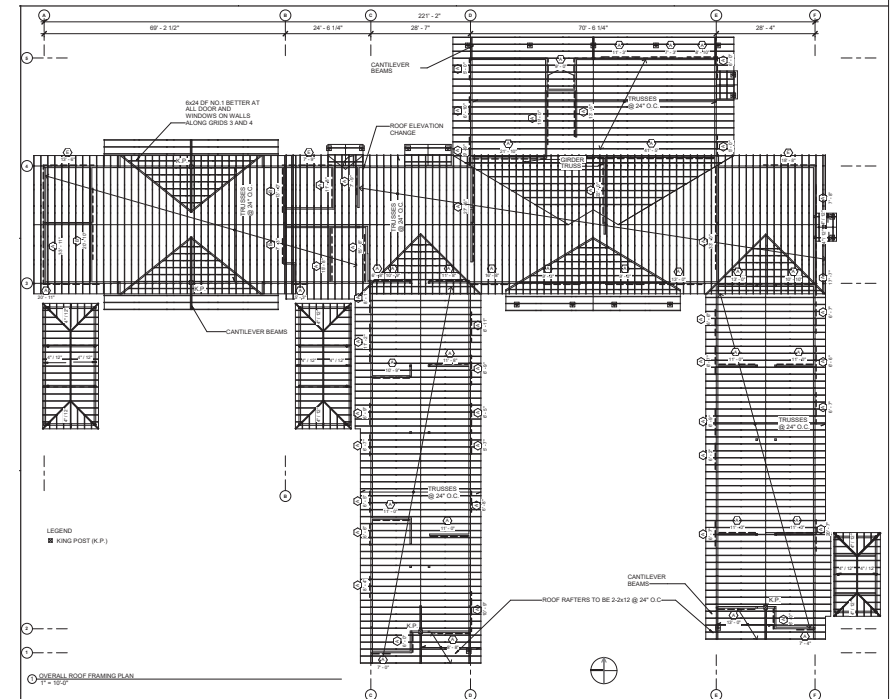

FIRE STATION AND HELITACK BASE, BIEBER, CA





RFRamer LLC
WE BUILD IT FIRST.

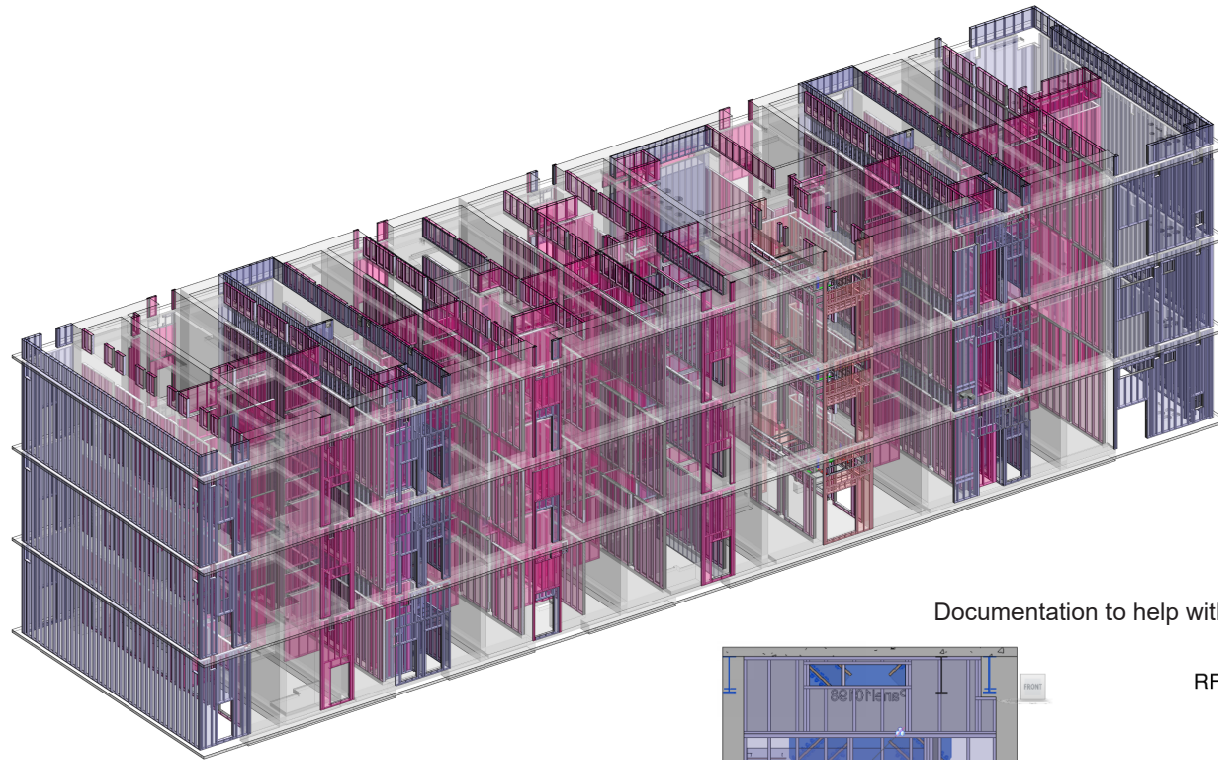

SCOPE: Wall framing and in-fill framing at MEPF penetrations
AREA: 2,850,015 SF
LEVELS: 66

Documentation to help with coordination meetings

RFIssue_26

Please review the structural steel obstructing the door opening in levels 47 and 49.

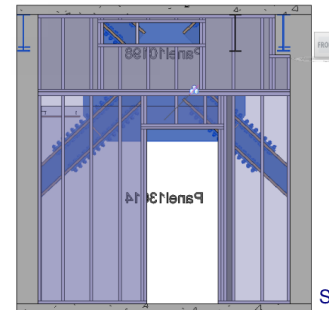
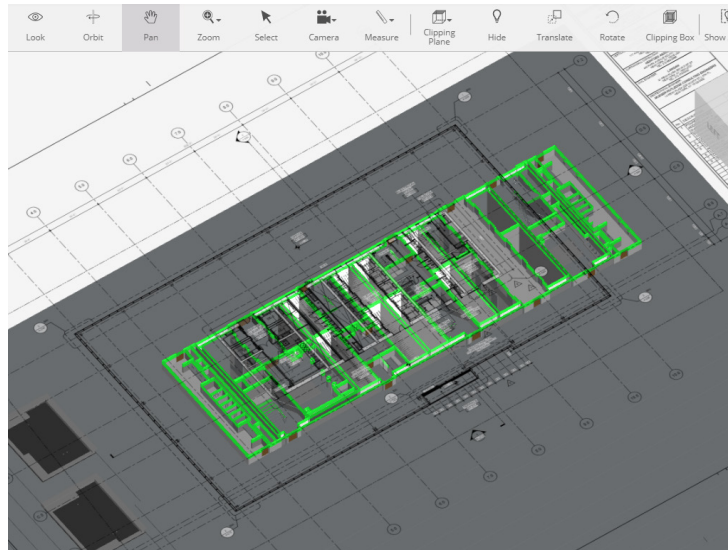

Snapshot from Revit

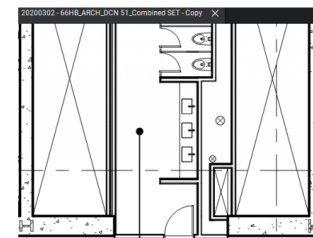

WOMEN'S WASHROOM
47-007

CORE PLAN - 47TH MECHANICAL FLOOR

Snapshot from Navis

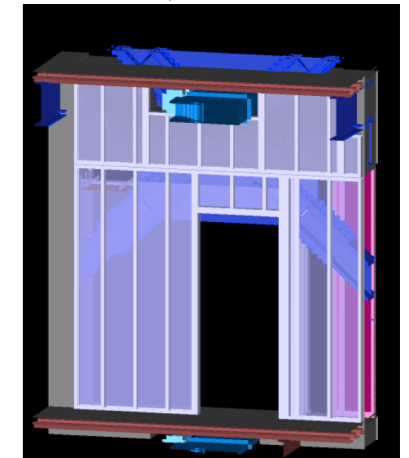



RFrame LLC
WE BUILD IT FIRST.

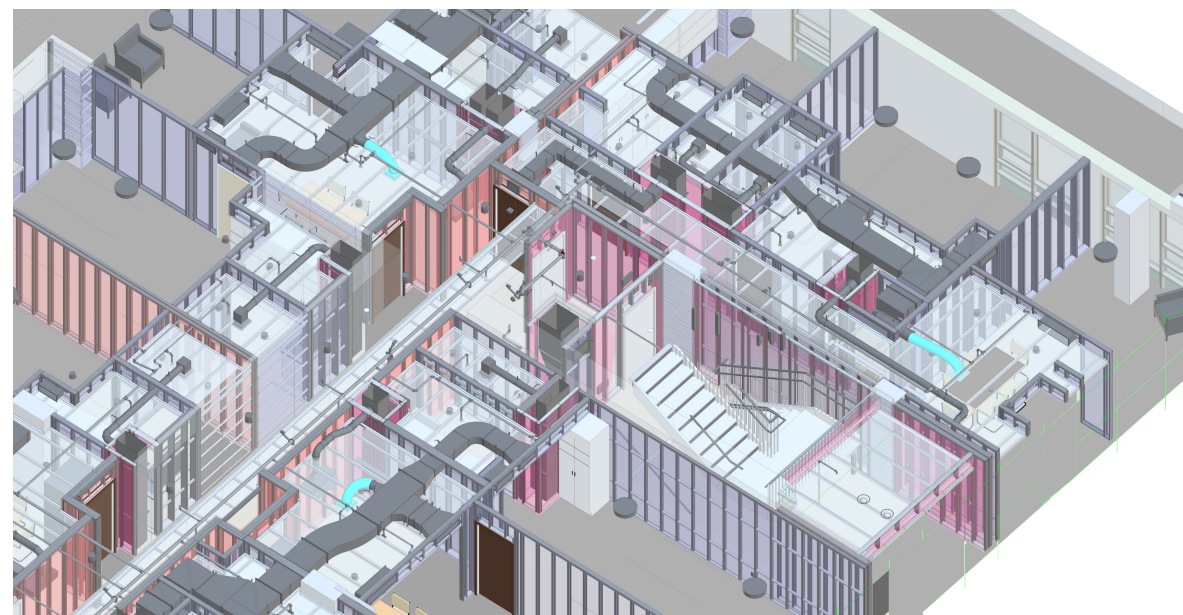
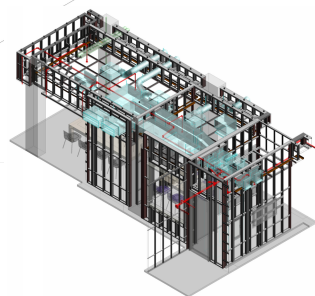
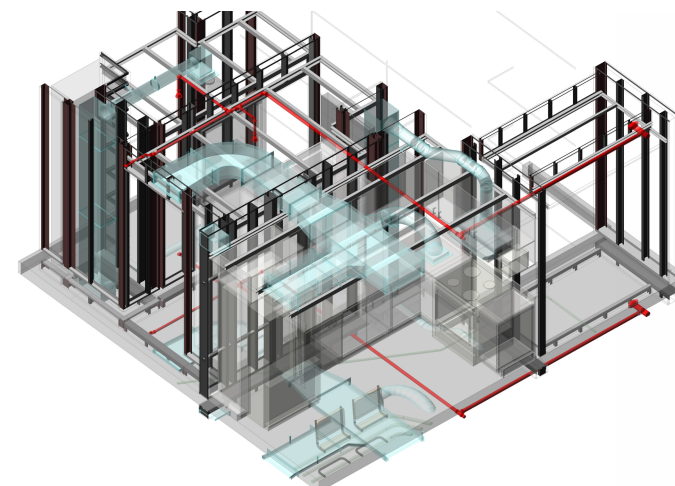
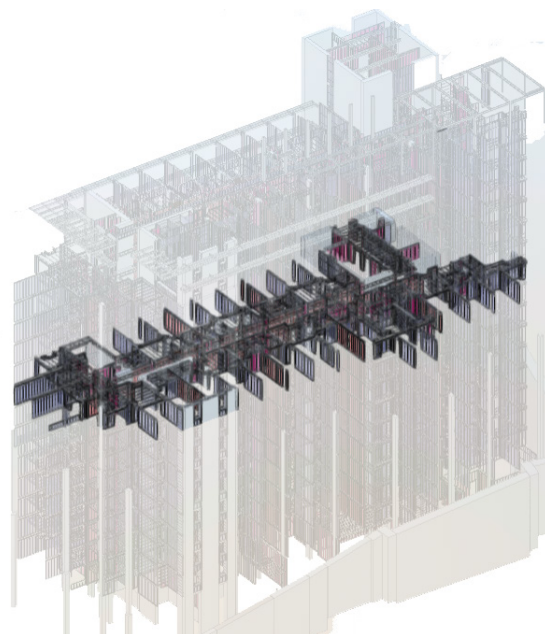

SCOPE: Wall and ceiling framing
with MEPF coordination.

AREA: 302,008 SF

LEVELS: 19

STUDENT HOUSING, LOS ANGELES, CA



RFRamer LLC
WE BUILD IT FIRST.

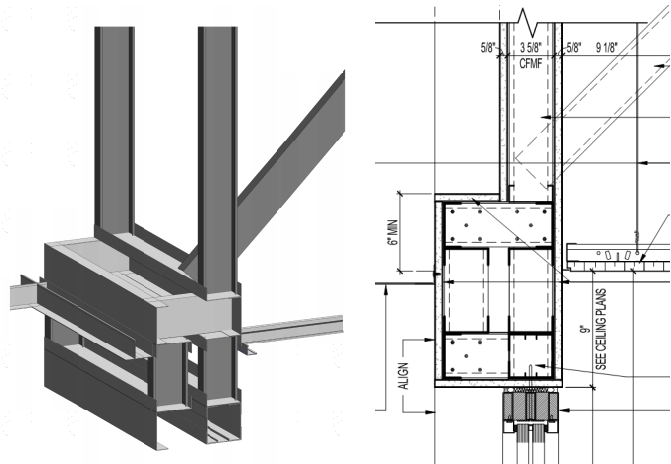

Framing per detail

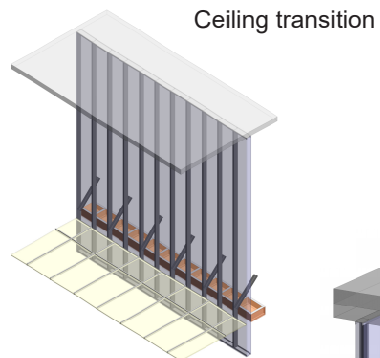

Ceiling transition

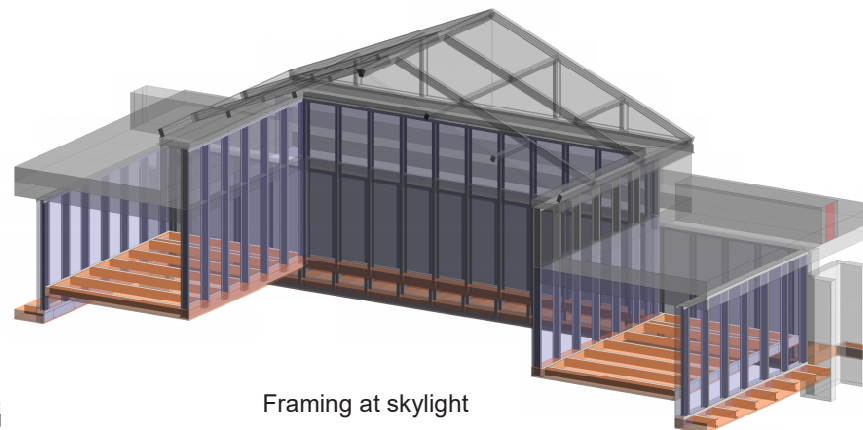

Framing at skylight

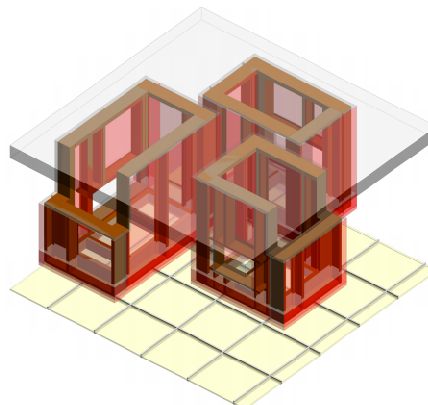
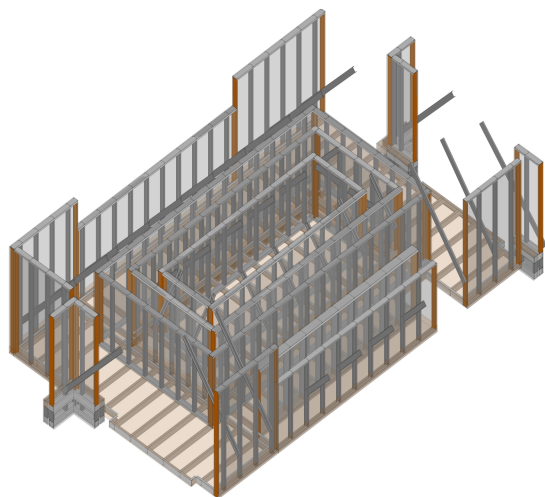

Framing at hanging shafts

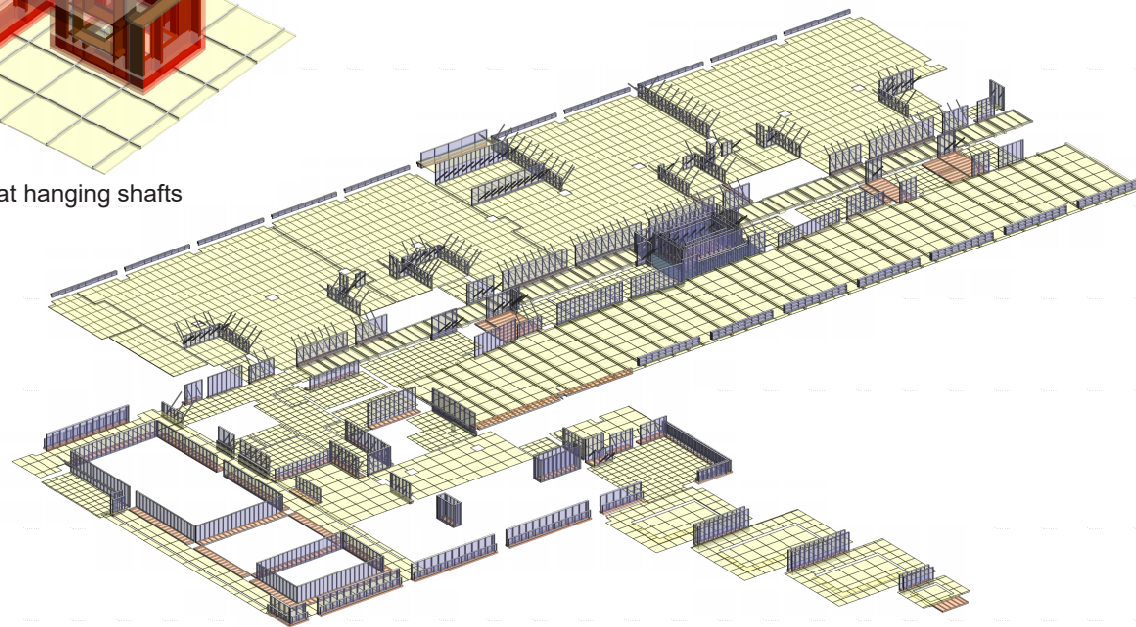

SCOPE: Ceiling framing as per details.

AREA: 235,000 SF

LEVELS: 6

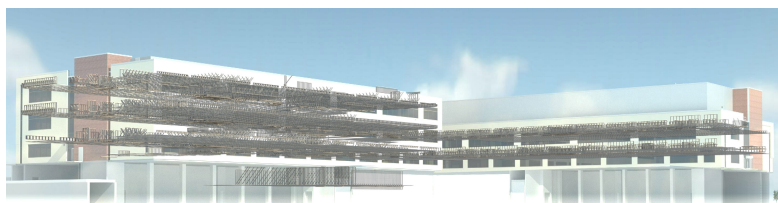

BIOTECH COMPANY, LAWRENCEVILLE, NJ



RFrame LLC
WE BUILD IT FIRST.

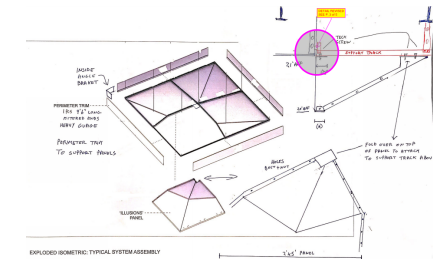
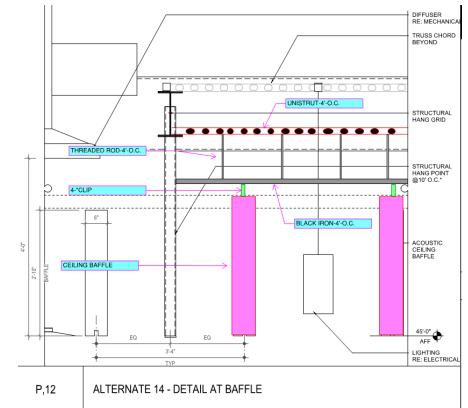
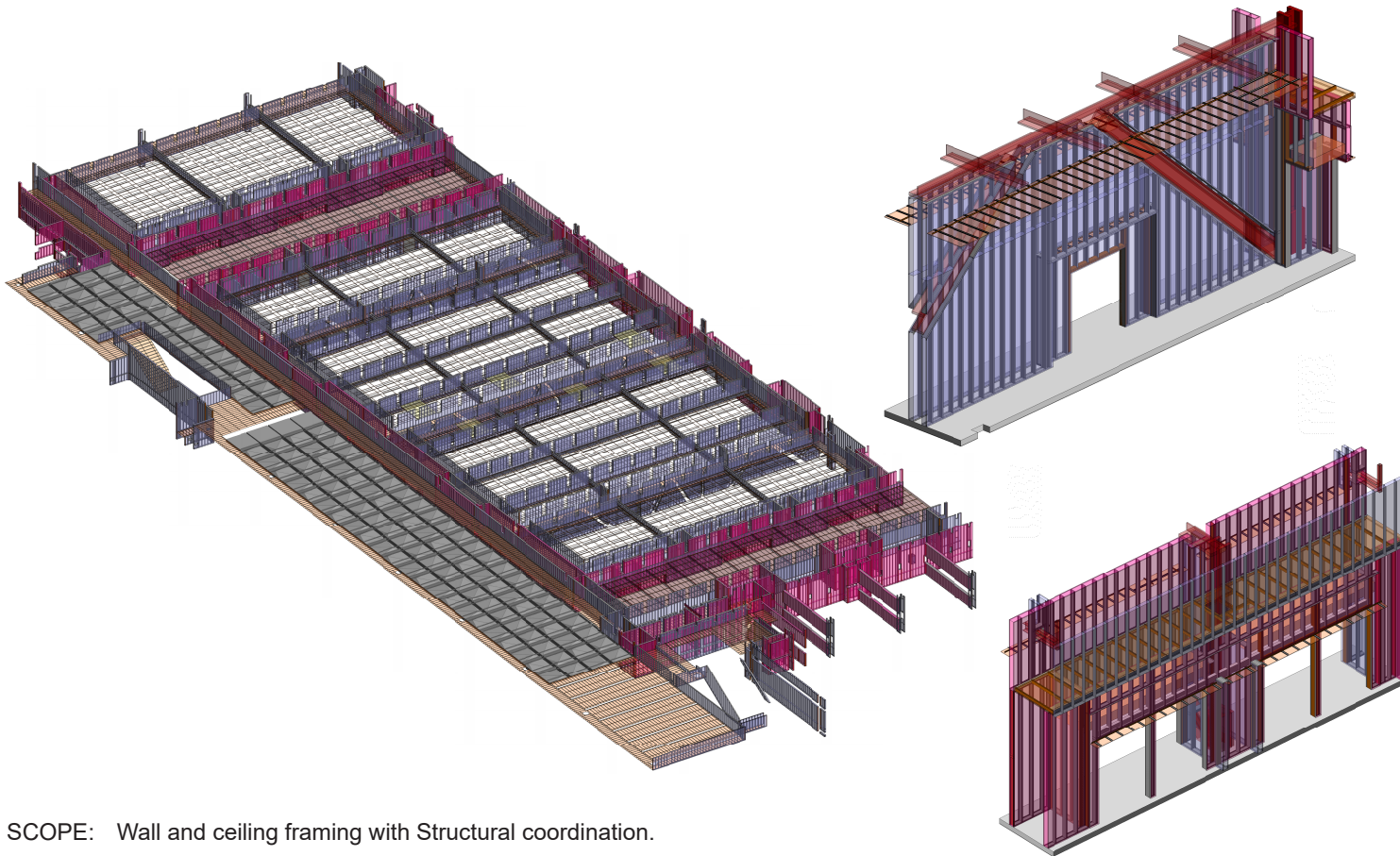

Ceiling framing sketches

SCOPE: Wall and ceiling framing with Structural coordination.
AREA: 1,215,291 SF
LEVELS: 6

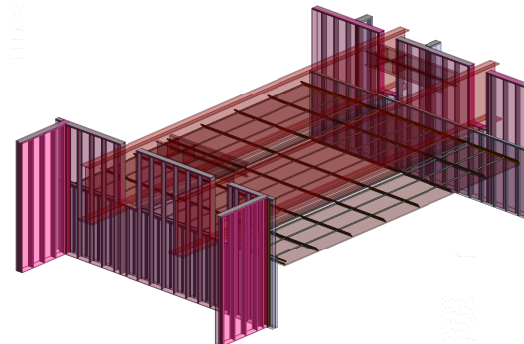
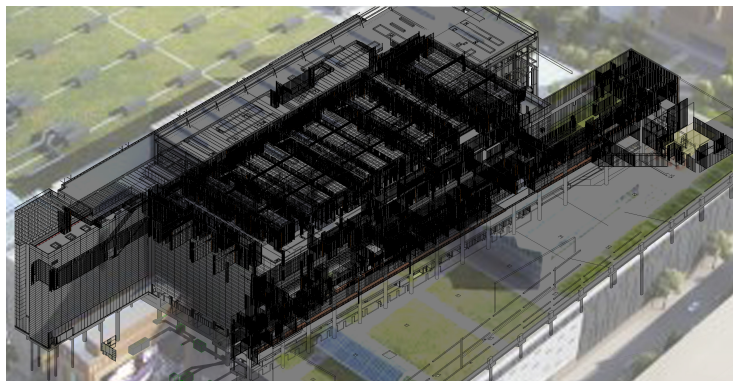

FLOOR PLAN														
LEVEL	ZONE	SHEET No.	DCN	33	34	35	36	37	38	39	40	41	42	Current working bulletin
L00	21	A2-0-21												41
L01	17S	A2-1-17												41
L01	18S	A2-1-18												41
L01	19S	A2-1-19												41
L01	20S	A2-1-20												36
L01	17E	A2-1-17												35
L01	18E	A2-1-18												37
L01	19E	A2-1-19												41
L01	20E	A2-1-20												40
L01	21	A2-1-21												41
L01	22	A2-1-22												NA
L01	23	A2-1-23												NA
L01	24	A2-1-24												34

Tracking design changes

CONVENTION CENTER, NEW YORK, NY



RFrame LLC
WE BUILD IT FIRST.

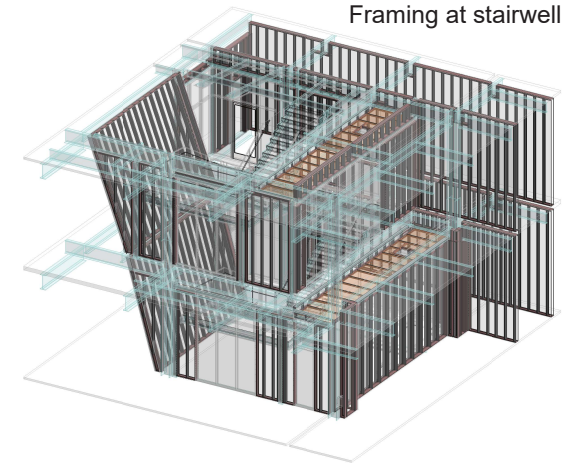
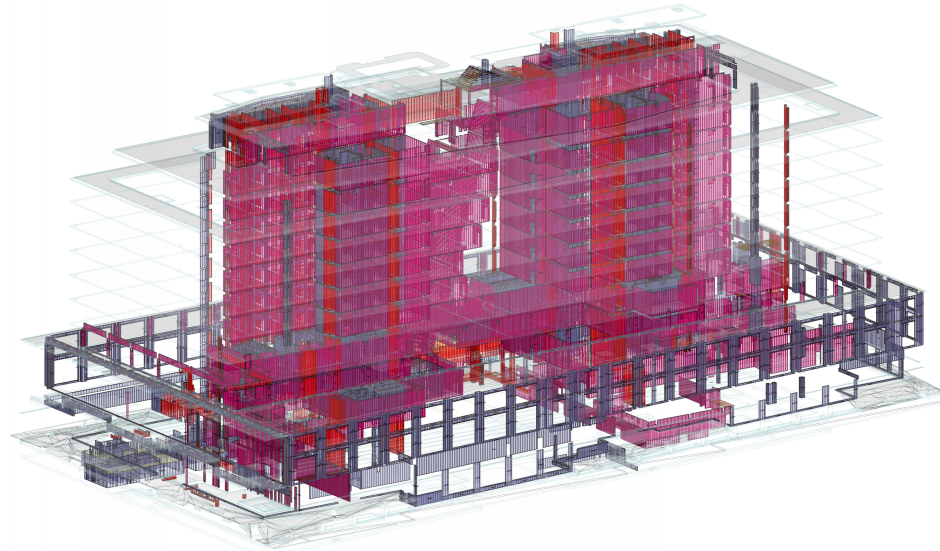
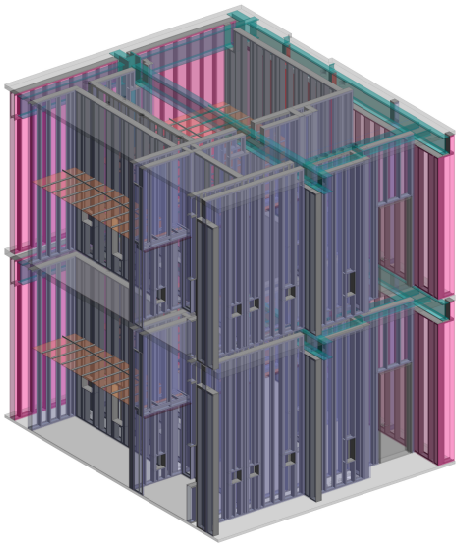

Framing at stairwell

SCOPE: Wall and ceiling framing with
Structural coordination.

AREA: 1,300,000 SF

LEVELS: 12

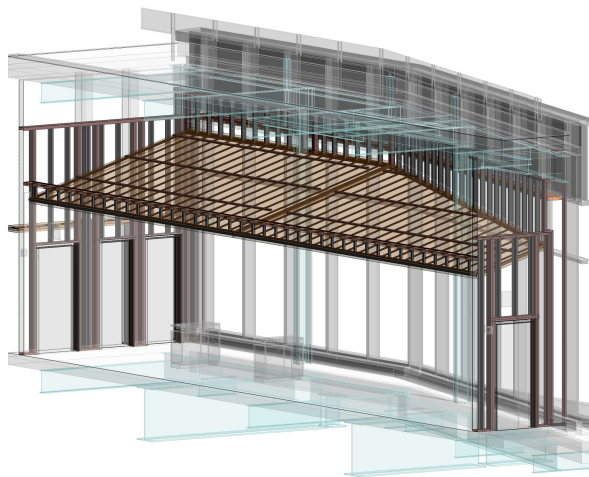

Custom ceiling framing

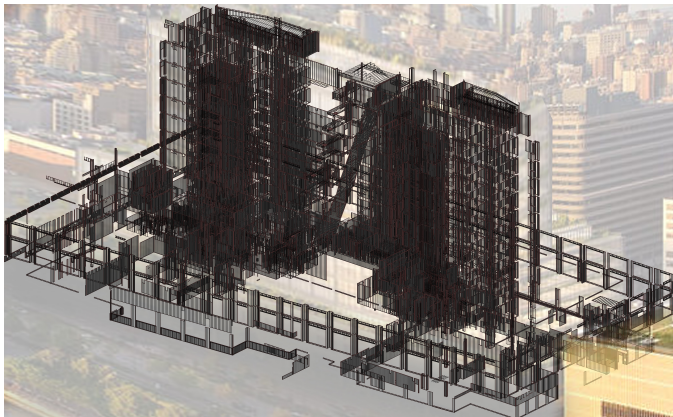
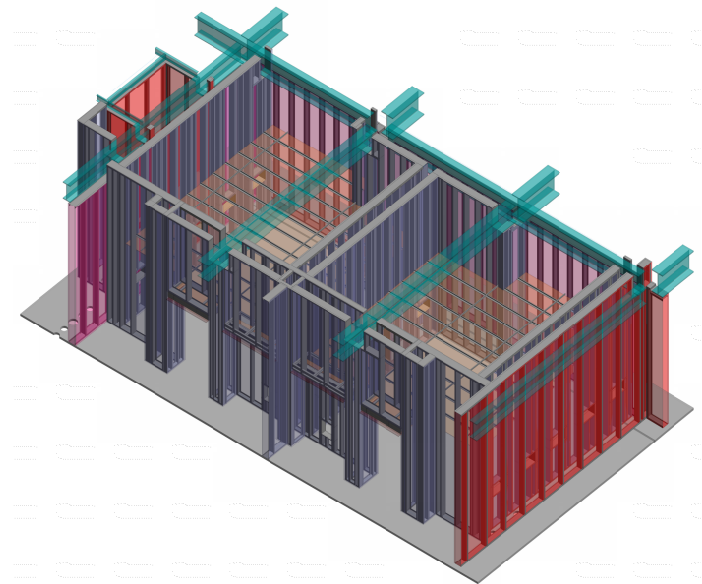

COMMERCIAL BUILDING, NEW YORK, NY



RFrame LLC
WE BUILD IT FIRST.

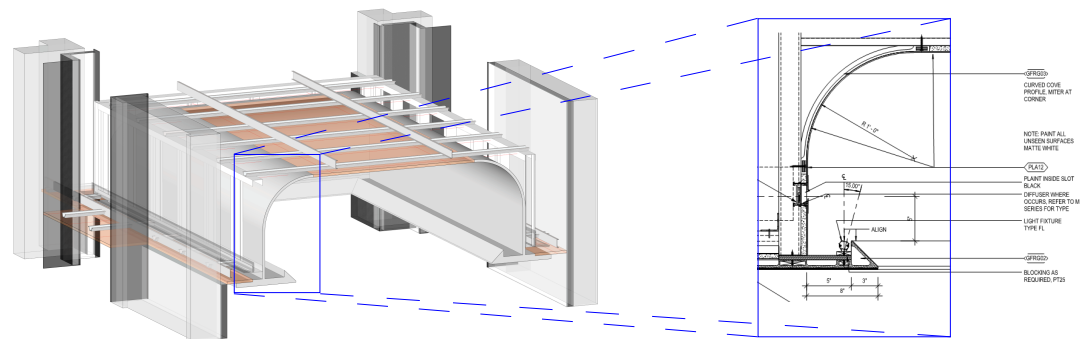

Curved light cove detail

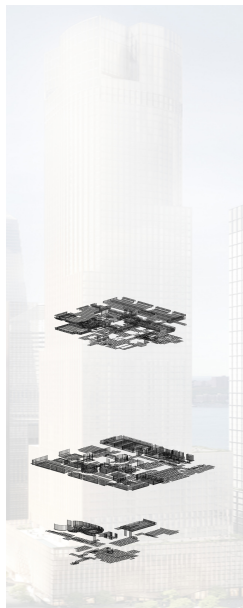
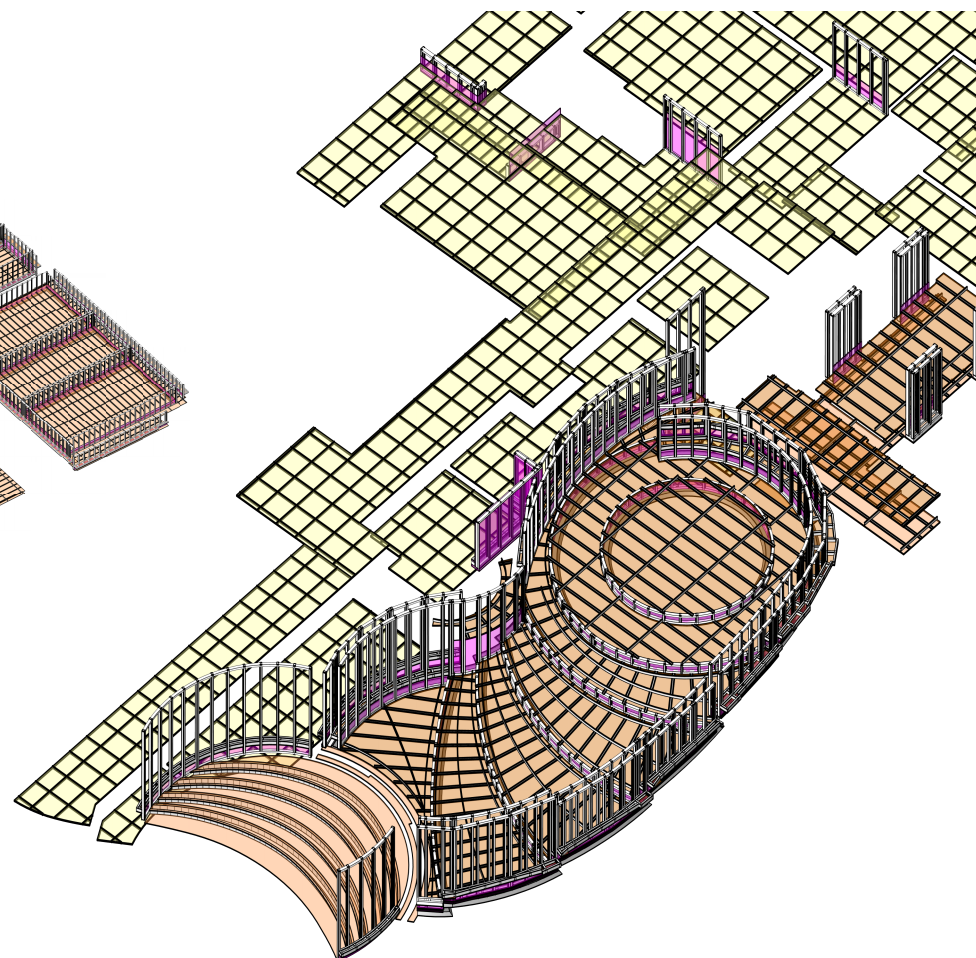
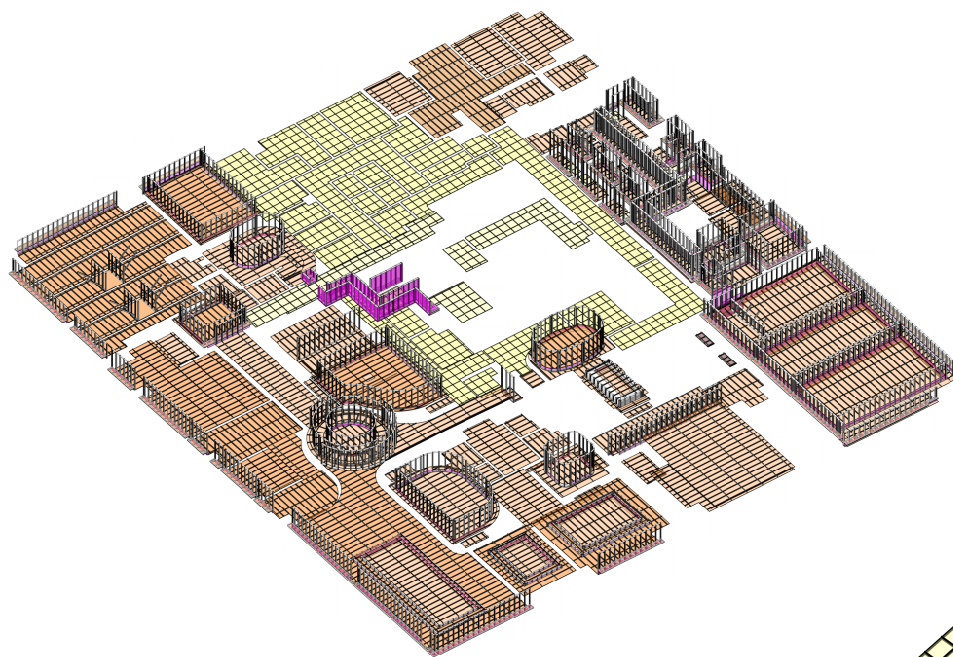

SCOPE: Ceiling framing as per details.

AREA: 1,100,000 SF

LEVELS: 5 of 72 In Scope

RESIDENTIAL BUILDING, NEW YORK, NY



RFrame LLC
WE BUILD IT FIRST.

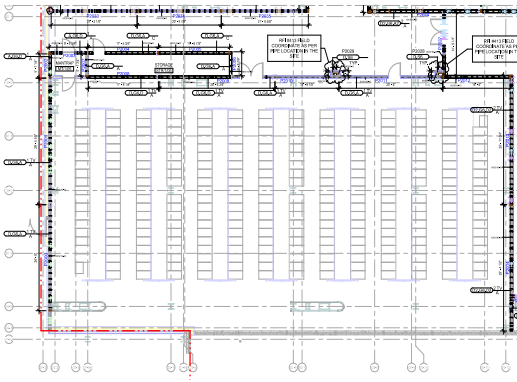

Floor Plan layout with Panel numbers

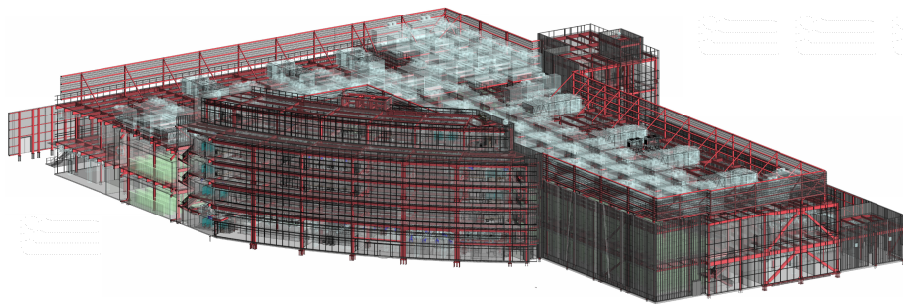
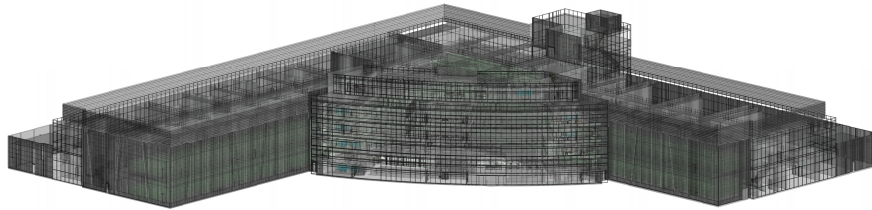
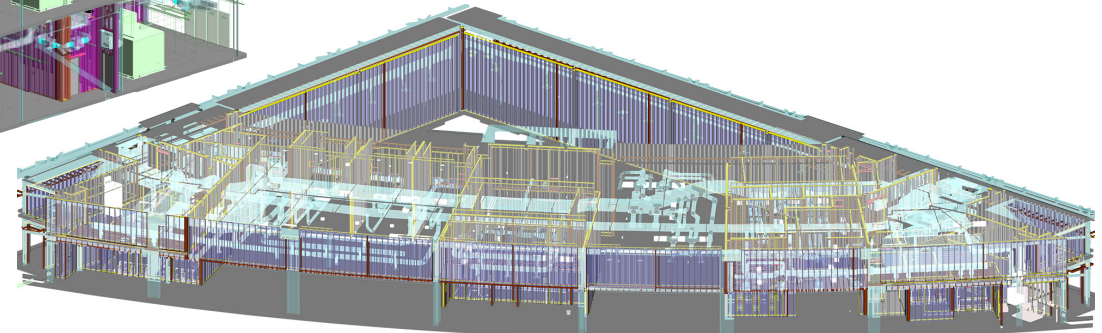
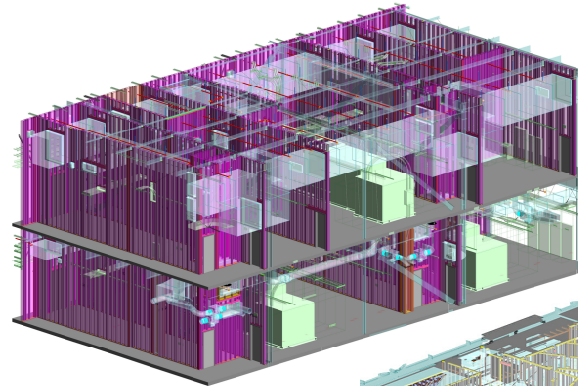

SCOPE: Wall and ceiling framing with MEPF coordination.

Producing panel drawings for site execution.

AREA: 287,000 SF

LEVELS: 5

P3005 - Framing Cut List

Lbl	Qty	Member	Length	Prefab Length
B0	1	600SLT250-54	11'- 3"	
B1	1	600SLT250-54	6'- 11"	
B2	1	600SLT250-54	6'- 5 5/8"	
B3	1	600T250-54	1'- 1 3/4"	
B4	1	600T250-54	1'- 1 1/4"	
B5	1	600T250-54	0'- 7"	
B6	1	600SLT250-54	0'- 6 3/8"	
B7	1	600T250-54	0'- 6"	
B8	1	600T150-33	0'- 4"	
B9	1	600T150-54	28'- 6"	
B10	2	600S162-54	8'- 10 1/4"	
B11	2	600T150-54	8'- 6 1/4"	
B12	1	600T150-43	0'- 3 1/2"	
B13	1	600XT425-54(50)	0'- 3 1/2"	
B14	2	600T150-33	4'- 1 1/4"	
B15	1	600X425-33(33)	4'- 1 1/4"	
B16	4	600T150-33	4'- 1"	
B17	3	600X425-33(33)	4'- 1"	
B18	1	600T150-33	2'- 9 1/2"	
B19	1	600T250-54	2'- 9 1/2"	
B20	1	600T150-33	2'- 4 1/2"	
B21	1	600T250-54	2'- 4 1/2"	
C0	1	600S162-43	20'- 3 1/2"	
C1	5	600S200-54	20'- 3 1/2"	
C2	4	600S200-68	20'- 3 1/2"	
C3	2	600S162-43	17'- 9 3/8"	
C4	2	600S200-54	19'- 10 1/2"	
C5	13	600S162-43	13'- 5"	
C6	3	600S200-54	13'- 5"	
C7	4	600S162-43	11'- 6 1/8"	
C8	12	600S162-43	4'- 2 1/4"	
C9	2	600S200-54	4'- 2 1/4"	
C10	1	600S200-54	3'- 10 5/8"	
C11	1	600S162-43	3'- 10 5/8"	
C12	1	600S200-68	3'- 10 5/8"	
C13	1	600S200-68	2'- 10 1/4"	
C14	1	600S162-43	2'- 7 1/4"	
C15	1	600S200-54	1'- 10"	
C16	3	600S162-43	1'- 10"	
C17	1	600T150-33	1'- 3 3/8"	
C18	4	600S162-43	0'- 6 7/8"	
C19	4	600S162-43	0'- 4 1/8"	
Grand Total: 99				

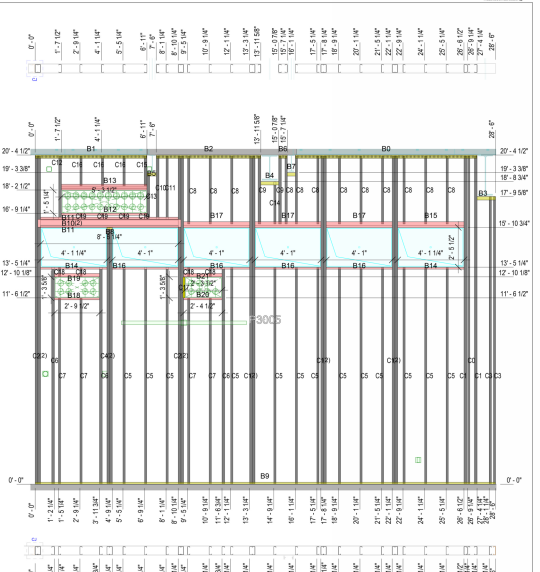
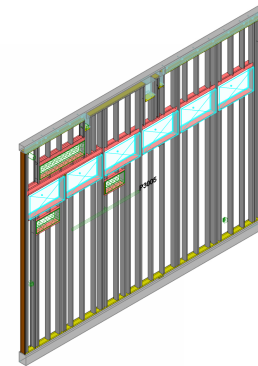

	PROJECT INFO	DATE	REVISIONS	PANEL PARTITION TYPE	FRAMING MEMBERS LEGEND	TRADE LEGEND & LINK DATE	INTERNAL QC STAMP	PANEL LOCATION
	DATA CENTER San Jose, CA			D.G6.A 1 A	TRACK BEAM HEADER/BILL JAMB	CONTROL JOINT - CJ HINT - ID Z.CLP STEEL FIRE PROTECTION	SM QC	W2.6.1 PANEL # P3005

Panel drawing for pre-fabrication and site execution

DATA CENTER, SAN JOSE, CA

